

PRODUCT SPECIFICATIONS

Halsey Taylor Countertop Fountain, Non-Filtered Non-Refrigerated Stainless. Furnished with Push Button bubbler. Mechanical Top Bubbler Button activation. Product shall be Countertop mounted, for Indoor + Outdoor applications, serving 1 station(s). Unit shall be lead-free design which is certified to NSF/ANSI 61 & 372 (lead free) and meets Federal and State low-lead requirements.

Order ID:	74060005000
Finish:	Stainless Steel
Power:	No Electrical Required
Bubbler Style:	Push Button
Activation by:	Mechanical Top Bubbler Button
Mounting Type:	Countertop
Chilling Option:	Non-refrigerated
Dimensions (L x W x H):	12-1/4" x 8-1/4" x 11-7/8"
Approx. Shipping Weight:	5 lbs.
Installation Location:	Indoor + Outdoor
No. of Stations Served:	1

- Mechanically-Activated bubbler continues to supply water in event of service disruptions.



AMERICAN PRIDE. A LIFETIME TRADITION. Like your family, the Elkay family has values and traditions that endure. For almost a century, Elkay has been a family-owned and operated company, providing thousands of jobs that support our families and communities.



Included with Product: Fountain

PRODUCT COMPLIANCE

ASME A112.19.3/CSA B45.4

Buy American Act

NSF/ANSI 61 & 372 (lead free)



[Installation Instructions \(PDF\)](#)

Water Systems are warranted for 12 months from date of installation.

Warranty pertains to drinking water applications only. Non-drinking water applications are not covered under warranty.

[Warranty \(PDF\)](#)

OPTIONAL ACCESSORIES

HWF172 - WaterSentry VII Filter Kit (Coolers + Fountains)
96852CA - Halsey Taylor Gooseneck Glass Filler Kit

PART: _____ QTY: _____

PROJECT: _____

CONTACT: _____

DATE: _____

NOTES: _____

APPROVAL: _____

In keeping with our policy of continuing product improvement, Halsey Taylor reserves the right to change product specifications without notice. Please visit Halseytaylor.com for the most current version of Halsey Taylor product specification sheets. This specification describes a Halsey Taylor product with design, quality, and functional benefits to the user. When making a comparison of other producers' offerings, be certain these features are not overlooked.

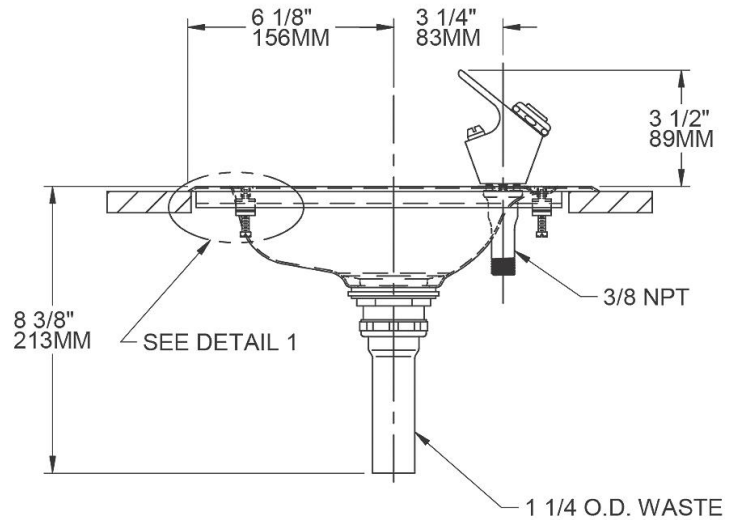
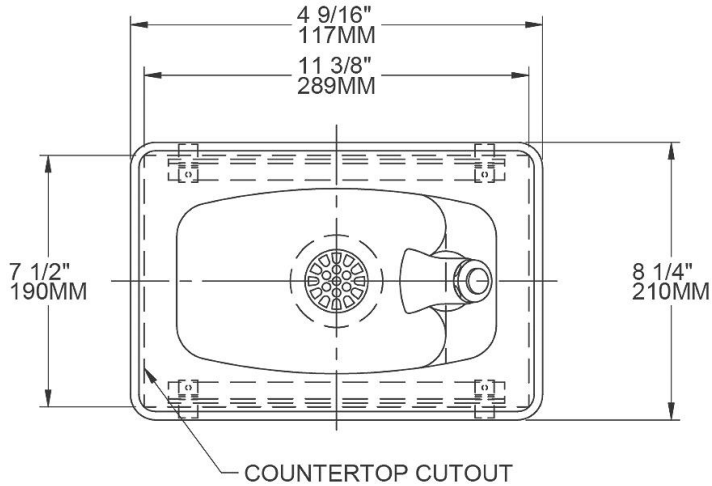
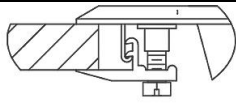

In keeping with our policy of continuing product improvement, Halsey Taylor reserves the right to change product specifications without notice. Please visit Halseytaylor.com for the most current version of Halsey Taylor product specification sheets. This specification describes a Halsey Taylor product with design, quality, and functional benefits to the user. When making a comparison of other producers' offerings, be certain these features are not overlooked.