

**PRODUCT SPECIFICATIONS**

Halsey Taylor Endura II Tubular Outdoor Fountain, Pedestal Non-Filtered Non-Refrigerated. Features shall include 316 Stainless, Heavy Duty Vandal-Resistant. Furnished with Vandal-Resistant bubbler. Front Button activation. Product shall be Floor Mount/Freestanding, for Outdoor applications, serving 1 station(s). Unit shall be lead-free design which is certified to NSF/ANSI 61 & 372 (lead free) and meets Federal and State low-lead requirements.

<b>Special Features:</b>	316 Stainless, Heavy Duty Vandal-Resistant
<b>Finish:</b>	Beige (BGE), Black (BLK), Blue (BLU), Brown (BRN), Evergreen (EVG), Gray (GRY), Orange (ORN), Purple (PUR), Red (RED), Terracotta (TER), White (WHT), Yellow (YLW)
<b>Bubbler Style:</b>	Vandal-Resistant
<b>Activation by:</b>	Front Button
<b>Mounting Type:</b>	Floor Mount/Freestanding
<b>Chilling Option:</b>	Non-Refrigerated
<b>Approx. Shipping Weight:</b>	134 lbs.
<b>Installation Location:</b>	Outdoor
<b>No. of Stations Served:</b>	1

- Base material constructed from marine-grade 316 stainless steel provides the ultimate corrosion protection from even the most corrosive elements.
- Heavy Duty Vandal-Resistant:
  - Tamper resistant screws
  - Resists stains and corrosion
  - Heavy-gauge construction
- Vandal-resistant, bubblers are one-piece, chrome plated with integral hood guard design to prevent contamination from other users, airborne deposits and tampering.



**AMERICAN PRIDE. A LIFETIME TRADITION.**  
Like your family, the Elkay family has values and traditions that endure. For almost a century, Elkay has been a family-owned and operated company, providing thousands of jobs that support our families and communities.



**PRODUCT COMPLIANCE**

Buy American Act  
NSF/ANSI 61 & 372 (lead free)



[Installation Instructions \(PDF\)](#)

**Warranty pertains to drinking water applications only. Non-drinking water applications are not covered under warranty.**

[Warranty \(PDF\)](#)

**OPTIONAL ACCESSORIES**

4471LHB - Locking Hose Bib
97890C - Accessory - Direct Bury Adaptor

PART: \_\_\_\_\_ QTY: \_\_\_\_\_  
 PROJECT: \_\_\_\_\_  
 CONTACT: \_\_\_\_\_  
 DATE: \_\_\_\_\_  
 NOTES: \_\_\_\_\_  
 APPROVAL: \_\_\_\_\_

*In keeping with our policy of continuing product improvement, Halsey Taylor reserves the right to change product specifications without notice. Please visit Halseytaylor.com for the most current version of Halsey Taylor product specification sheets. This specification describes a Halsey Taylor product with design, quality, and functional benefits to the user. When making a comparison of other producers' offerings, be certain these features are not overlooked.*

**MOUNTING INSTRUCTIONS and PLUMBING CONNECTIONS**

Refer to diagrams for plumbing rough-in. This fountain is to be mounted on a smooth, flat finished wall surface with adequate support.

**Note:** Wall mounting structure must be capable of supporting 300lb. load minimum on fountain. To secure unit, use 3/8 minimum fasteners (not provided). Water service line and waste line are to be assembled as required. Final check for leaks and correct functions of fountain should be made. (For details see the installation instructions.)

**Installation requires trap to be installed in wall. A service supply stop must be installed at the fountain inlet line. Trap and service stop not included.**

**Caution - Fountain must be securely bolted to wall.**

**Note:** For wall support required locations see installation instructions provided with fountain.

OPERATING PRESSURES:  
Supply water 20 – 105 psi maximum

**TOP VIEW**

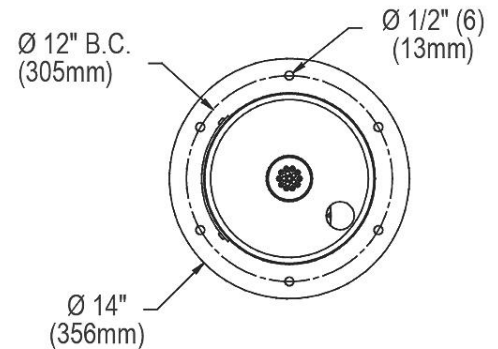

**SIDE VIEW**

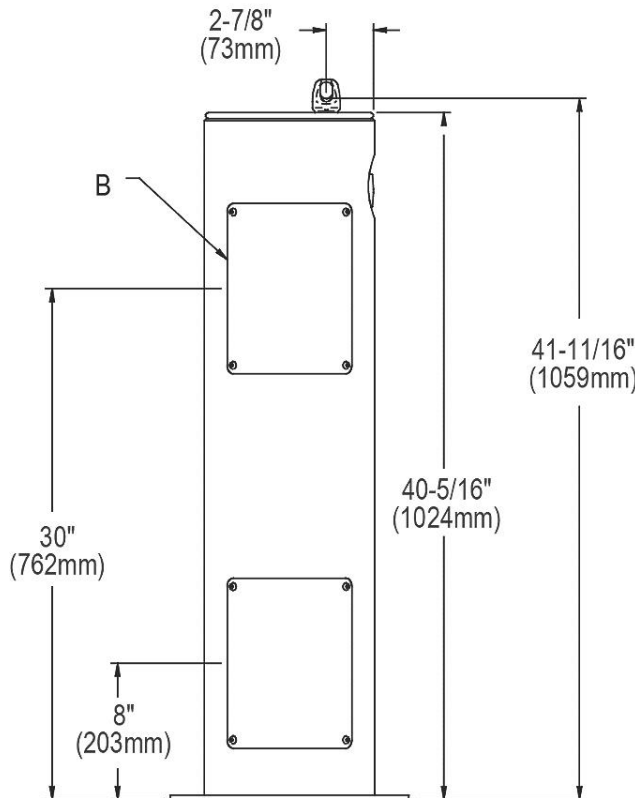

**FRONT VIEW**

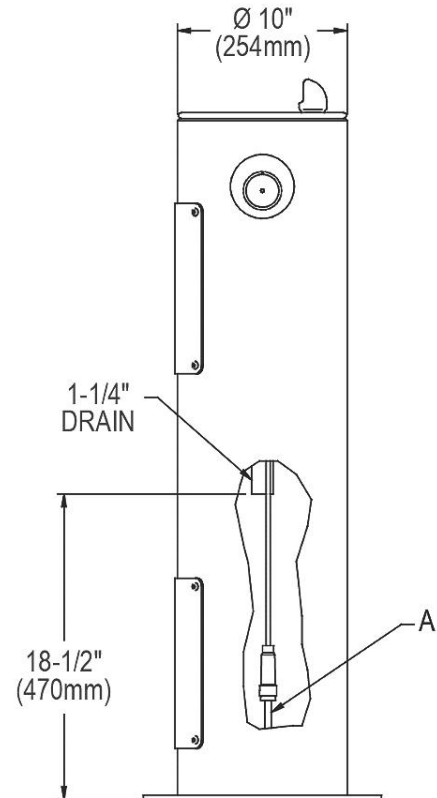

A = 3/8" O.D. UNPLATED COPPER TUBE CONNECT  
SHUT OFF VALVE BY OTHERS  
B = ACCESS PANEL (8" x 10")

*In keeping with our policy of continuing product improvement, Halsey Taylor reserves the right to change product specifications without notice. Please visit [Halseytaylor.com](http://Halseytaylor.com) for the most current version of Halsey Taylor product specification sheets. This specification describes a Halsey Taylor product with design, quality, and functional benefits to the user. When making a comparison of other producers' offerings, be certain these features are not overlooked.*