



# Molded Wood Premium Elongated Toilet Seat

## Product Specifications

### Description

Closed front with cover, elongated, molded wood, multi-coat enamel finish toilet seat. Features two color-matched bumpers and color-matched easy release hinges with non-corrosive, top-tightening bolts and wing nuts.

### Model: ML1525EC

Specifications	
Size:	Elongated
Weight:	8.60 lbs
Color:	White (000), Biscuit (346)
Material:	Molded Wood
Style:	Closed Front with Cover
Bumpers:	Two
Hinges:	Plastic Easy Release
Fastening System:	Non-Corrosive Top-Tightening Bolts and Wing Nuts



PLASTIC EASY RELEASE HINGES



TWIST HINGES TO UNLOCK



EASY REMOVAL OF SEAT FOR THOROUGH CLEANING



NON-CORROSIVE BOLTS AND WING NUTS

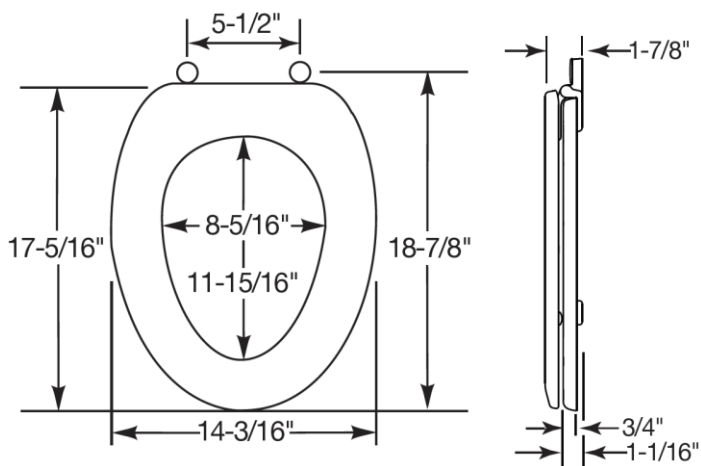

### Warranty

See warranty information for more details.

All dimensions listed are nominal. MAINLINE® reserves the right to make product and material changes at any time without notice.

Contact your sales representative for more information or visit our website at [mainlinecollection.com](http://mainlinecollection.com)